

Datasheet

8m Airboat – P362

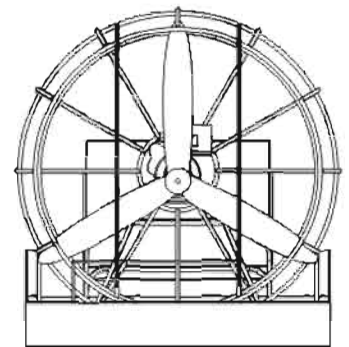
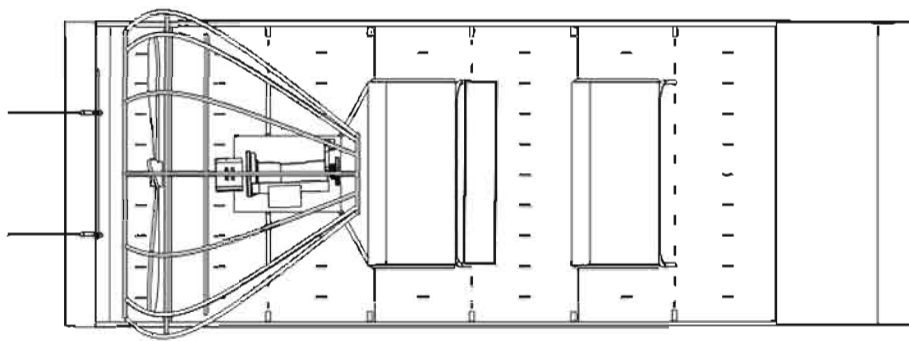
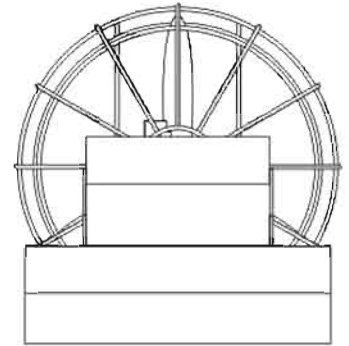
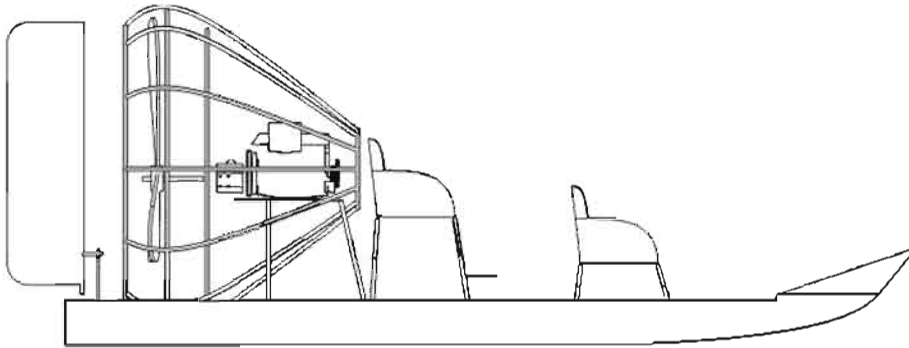

Dimensional Data

Length Overall	8000 mm
Beam	3000 mm
Displacement	1.7t
Fuel Capacity	200 L
Deadrise angle @ transom	0 deg
Freeboard @ amidships	400 mm
Max passengers	5
Berths	n.a
WC	n.a

- Aluminum construction
- Non slip deck
- Manual and electric bilge pump
- Safety equipment to meet class approval
- CUSTOM design option to meet the clients requirement

Engine Data

Max Power recommended

Hp	Max Speed,knt	Cruise Speed,knt	Range @ Cruise,nm	Endurance, hours
450	41	30	143	5

Options and Accessories

- Various seating arrangement
- A-Frame with self-righting bag
- Lifting point x 4
- Quick release tow hook

Design

ASIS Boats

Certification

CE / ISO

Propulsion

Fan Propulsion

ADDRESS

ASIS Boats L.L.C.
Industrial Area 3, Jebel Ali
Dubai, 81426, UAE

TELEPHONE

+971 4 880 4441

EMAIL
WEBSITE

info@asisboats.com
www.asisboats.com

*Please note that this is a non contractual document.
We reserve the right to make changes without notice.

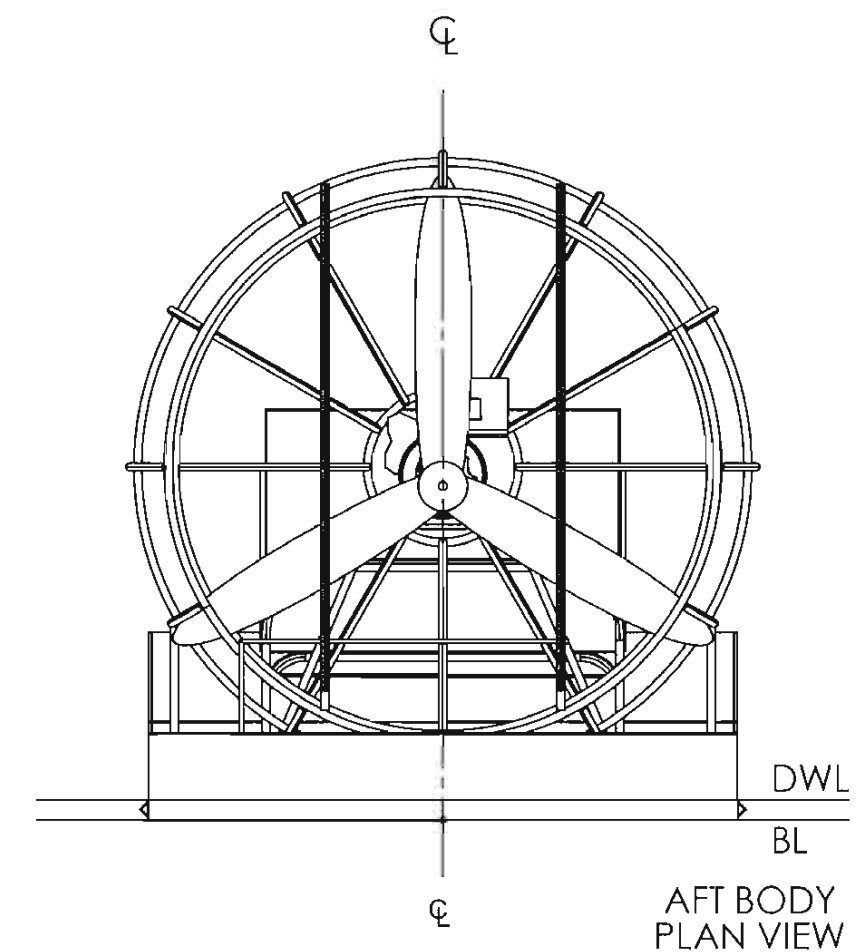
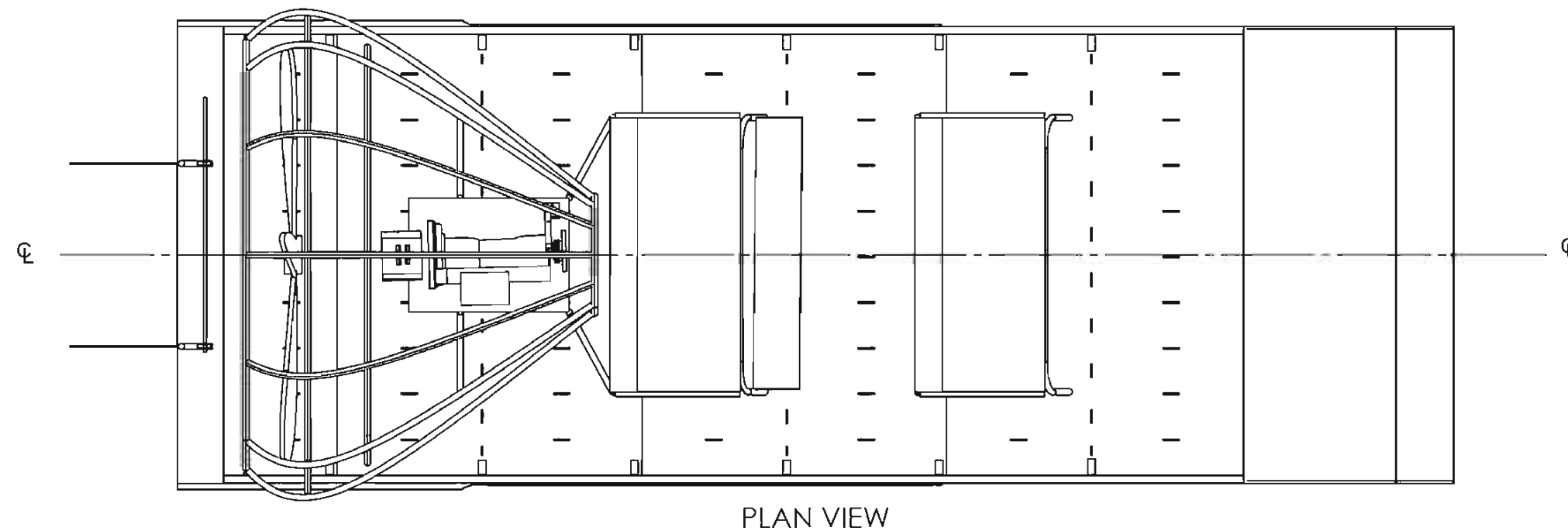
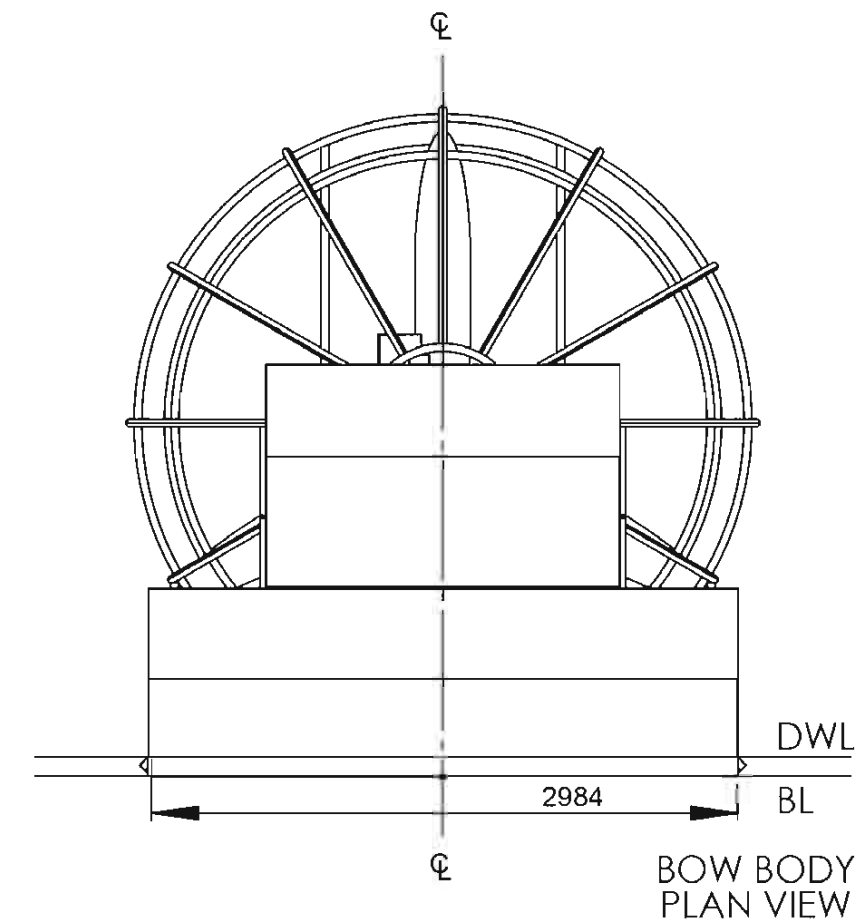
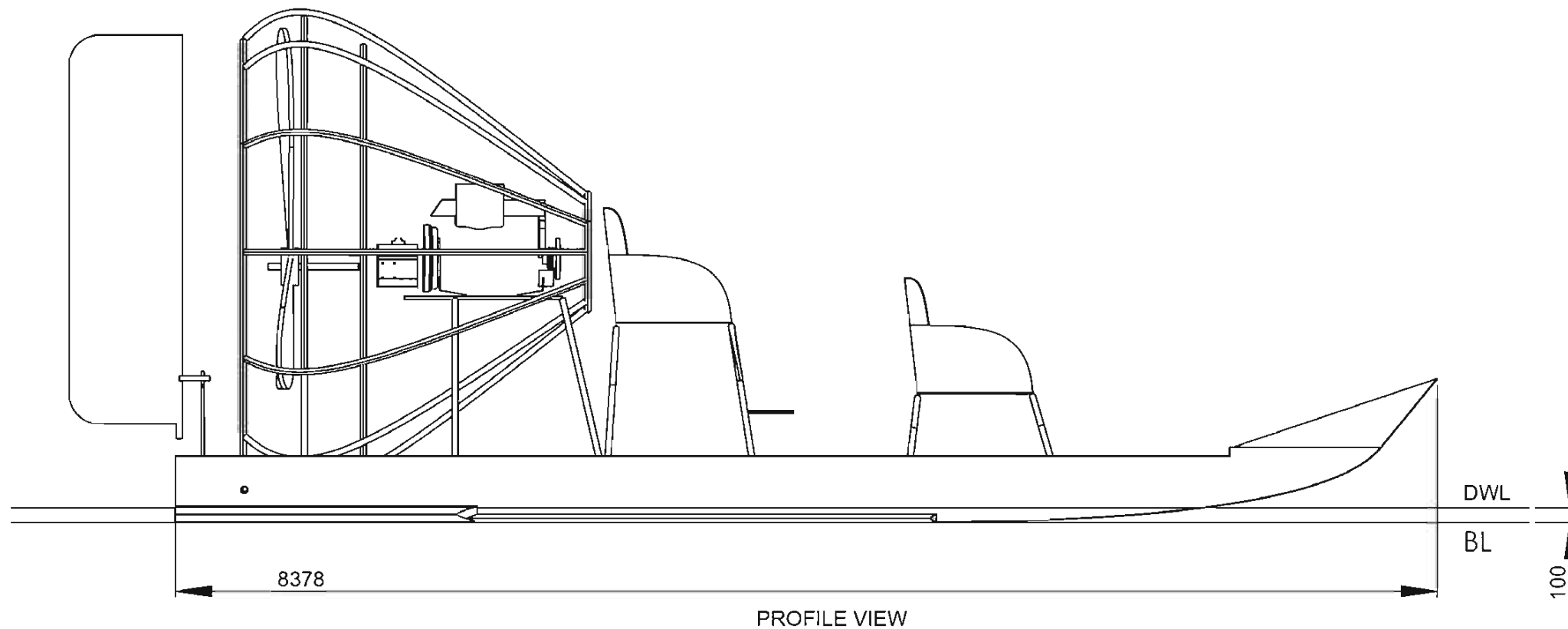

Copyright:
The intellectual property within this drawing is covered by the copyright and design legislation. It shall not be copied or used by any person or organisation other than that for which it has been issued or without the express written permission of **ASIS**.

123.456 Part Numbers CL Centre Line
 123.456 Influential Part Numbers CM Alignment Markers
 ^ Scribe Mark TOP BOT Orientation Markers
 O Bend Mark FWD AFT Orientation Markers

Vessel: P362 8m SWAMP BOAT Revision: 0 Scale: 1:40
 Title: GENERAL ARRANGEMENT Drawn by: JB
 Drawing Nr. P362-000-000 Checked by: KP
 Material: Alu Plate 00mm (5083 - H321) Date: 2014/01/28

